

3.5A, 3.0-25.0V H-Bridge Driver

Description

The SA8345 is one channel H-Bridge driver IC, it provides integrated motor-driver solution for toys, robotics, consumer products and other low voltage or battery-powered motion control applications.

The SA8345 maximum operational voltage is 25.0V. It can supply up to 3.5A of output continuous current and 6.0A of output peak current. There is internal shutdown function for over-temperature protection and over-current protection ($I_{OCP} = 6.0\text{ A}$).

Package material is Pb-Free Product & RoHS compliant for the purpose of environmental protection and for sustainable development of the earth.

Features

- Operation voltage up to 25.0V
- Continuous current output up to 3.5A
- Peak current up to 6.0A
- $R_{DS(on)}$: 180-m Ω (HS + LS)
- Support PWM control
- Over current protection
- Over temperature protection
- UVLO protection
- Low standby current
- Low quiescent current
- ESOP8 package

Application

- Robotics (R/C servo, Sweeping robot)
- Toys (R/C car, R/C aircraft)
- Any relevant DC motor applications.

SA8345 Package & Simplified Application

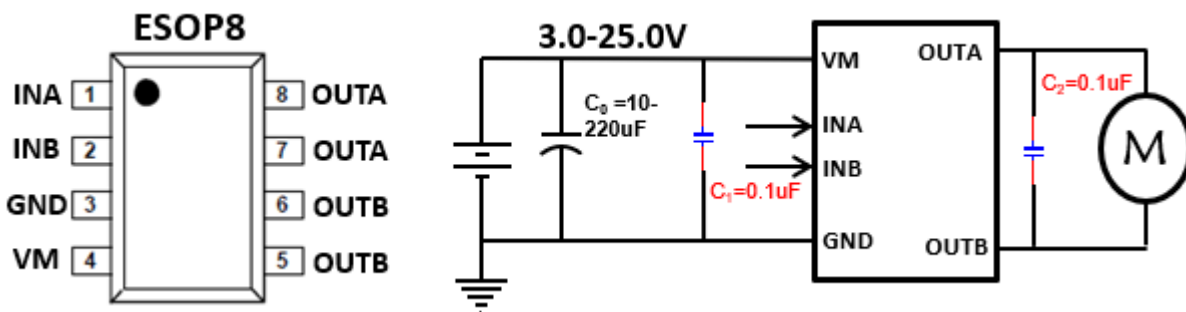

Device Information

Part No.	Package	Quantity	Operation Temp.
SA8345	ESOP8	4000	-40~85 °C

3.5A, 3.0-25.0V H-Bridge Driver

Pin Descriptions

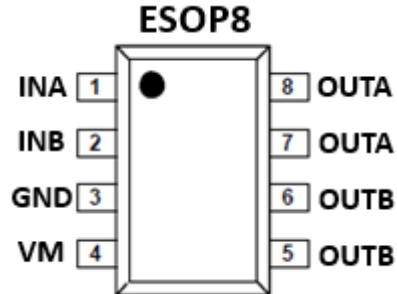

NO.	NAME	TYPE	DESCRIPTION
1	INA	I	Input INA
2	INB	I	Input INB
3	GND	P	Ground
4	VM	P	Power Supply for H-Bridge, Connection 10uF or bigger capacitor between VDD and GND
5	OUTB	O	Output OUTB
6	OUTB	O	Output OUTB
7	OUTA	O	Output OUTA, Connection 0.1uF between OUTA and OUTB
8	OUTA	O	Output OUTA, Connection 0.1uF between OUTA and OUTB

3.5A, 3.0-25.0V H-Bridge Driver

Absolute Maximum Ratings (T_A=25°C)

Parameter		Min.	Max.	Unit
Power Supply	V _M	-0.3	30	V
Input Logic	INA, INB	-0.3	7.0	
ESD(HBM)	V _M , INA, INB, OUTA, OUTB		4.0	kV
Operation temp.	T _J	-40	150	°C
Storage temp.	T _{stg}	-65	150	
Thermal resistance	θ _{JA}		60	°C/W

Recommended operating conditions (T_A=25°C)

Parameter		Min.	Max.	Unit
Power Supply	V _M	3.0	25.0	V
Input Logic	INA, INB	0	5.0	
Output Continuous Current	I _{OUTA} , I _{OUTB}	0	3.5*	A

Notes: * Using 25mm² FR4 Signal layer PCB (1 oz) under V_M=7.2V test.

Electrical Characteristics (V_M=7.2V, T_A=25 °C, R_{LOAD}=20)

Parameter		Test Condition	Min.	Typ.	Max.	Unit
H-Bridge FETs						
ON Resistance	R _{DSON}	I _{OUT} =1.0A		180		mΩ
INA/INB						
Input high level voltage	V _{INH}		2.0		5.0	V
Input low level voltage	V _{INL}		0		0.8	
Pull down resistance	R _{PD}			200	400	KΩ
Supply Current						
Standby current	I _{VM_OFF}	INA=INB=0		0	10	uA
Operation current	I _{VM_ON}			1.0	1.5	mA
Thermal Protection						
Thermal shutdown protection	T _{OTSD}			180		°C
Thermal shutdown hysteresis	T _{HYS}			60		

3.5A, 3.0-25.0V H-Bridge Driver

Block Diagram

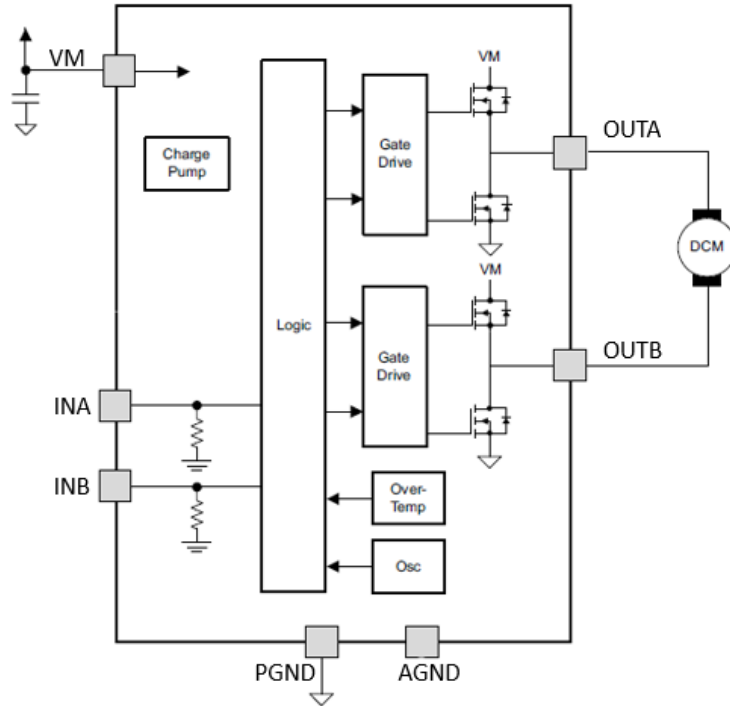

Truth Table

INA	INB	OUTA	OUTB	Mode	Supply Current
L	L	Hi-Z	Hi-Z	Stop	I_{VM_OFF}
H	L	H	L	Forward	I_{VM_ON}
L	H	L	H	Reverse	I_{VM_ON}
H	H	L	L	Brake	I_{VM_ON}

3.5A, 3.0-25.0V H-Bridge Driver

Application Notes:

1. Schematic Descriptions

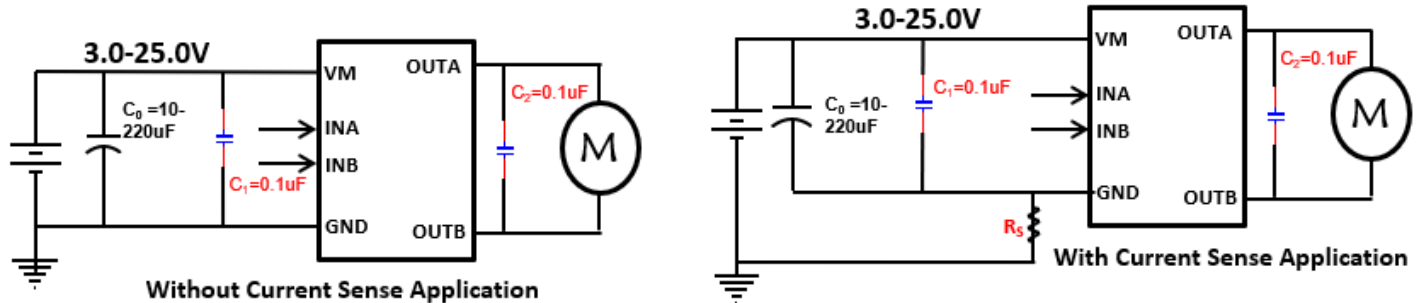

Notes :

1. This simplified schematic is only as reference in DC motor driver application.
2. C0, C1: Power supply VM pin capacitor:
 - 1) The capacitor can reduce the power spike when the motor is in motion. To avoid the IC directly damaged by the VM peak voltage. It also can stabilize the power supply voltage and reduce its ripples.
 - 2) The C0 capacitor can compensate power when motor starts running.
 - 3) The capacitor value determines the stability of the VM during motor in motion. If the large voltage power or a heavy loading motor is used, then a larger capacitor would be needed.
 - 4) On the PCB configuration, the C0, C1 must be mounted as close as possible to VM pin .
3. C2: The across-motor capacitor
 - 1) The C2 capacitors can reduce the power spike of motor in start running. A 0.1 μ F capacitor is recommended.
 - 2) The C2 capacitor must be added to the general application.
4. RS: The sense resistor in current sense application
 - 1) Need to sense output current, the RS is recommended to added between IC GND and PCB ground.
 - 2) The C0, C1 negative terminal is recommend connection to IC GND.

3.5A, 3.0-25.0V H-Bridge Driver

2. Operating Mode Descriptions

H-Bridge basic operating mode:

A) Stop mode

Definition : When $INA=INB=L$, then $OUTA=OUTB=Hi-Z$

B) Forward mode

Definition : When $INA=H$, $INB=L$, then $OUTA=H$, $OUTB=L$

C) Reverse mode

Definition : When $INA=L$, $INB=H$, then $OUTB=H$, $OUTA=L$

D) Brake mode

Definition : When $INA=INB=H$, then $OUTA=OUTB=L$

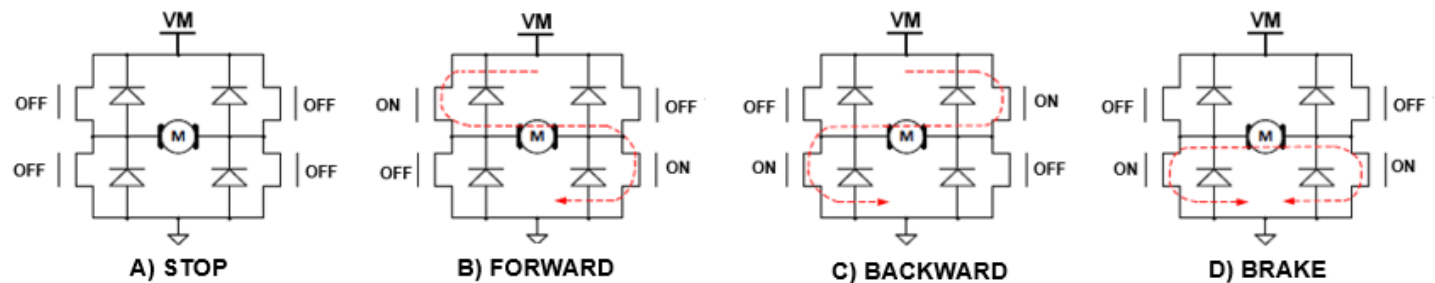

E) PWM mode A:

If input INA is PWM signal and $INB=0$ or if input INB is PWM signal and $INA=0$, then rotation speed of motor will be controlled by duty cycle of PWM signal. In this mode, motor drive circuit will be switched between switching-on and standby mode. In standby mode, all the power transistors are in off state, the energy stored in motor can only be released slowly from power MOSFET body diode.

Note that rotation speed of motor cannot be precisely controlled by duty cycle of PWM signal as there is a high-impedance state in working mode. If frequency of PWM signal is too high, then the case that motor cannot be started would occur.

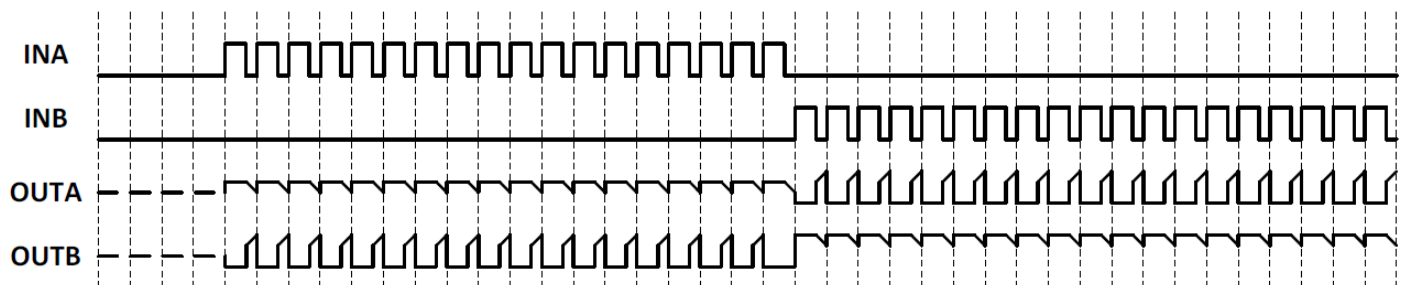

Input-Output in PWM mode A

3.5A, 3.0-25.0V H-Bridge Driver

F) PWM mode B:

If input INA is PWM signal and INB=1 or if input INB is PWM signal and INA=1, then rotation speed of motor will be controlled by duty cycle of PWM signal. In this mode, motor drive circuit output will be switched between switching-on and brake mode. In brake mode, the energy stored in motor will be released rapidly from low-side NMOS transistor.

Note that rotation speed of motor can be precisely controlled by duty cycle of PWM signal as there is a brake state in working mode and the energy of motor can be released quickly. However, it must be noted that, if frequency of PWM signal is too low, the case that motor cannot be rotated continuously and smoothly due to entering brake mode would occur. To reduce noise of motor, it is recommended that frequency of PWM signal be between 10 KHz and 50 KHz.

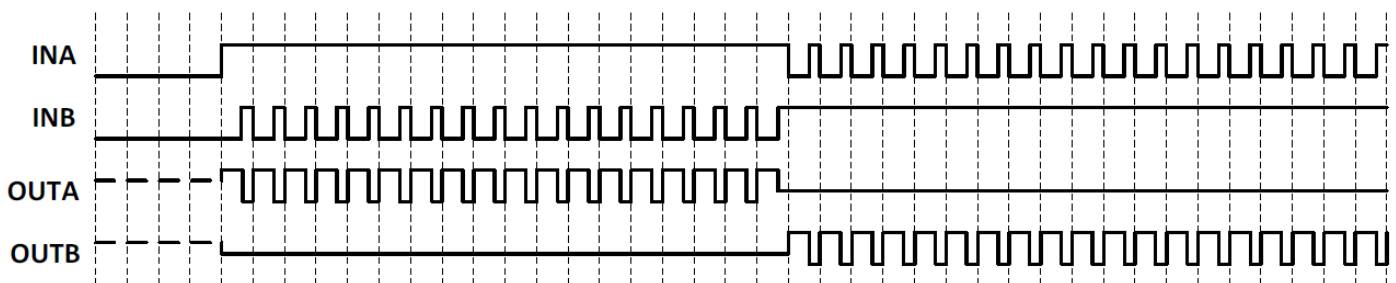

Input-Output in PWM mode B

3. Anti-common mode switching-on circuit

In full-bridge drive circuit, the state where both the high-side NMOS power transistor and the low-side NMOS power transistor are switched on at the same time in half bridge is called the common-mode switching-on state. In the common-mode switching-on state there is a power-to-ground, transient, high current, which would cause an extra power loss, and, in extreme cases, would burn the circuit down. With built-in dead time, the common mode switching-on state can be avoided. The typical dead time is 250ns.

4. Thermal protection circuit

If junction temperature of drive circuit exceeds a preset temperature (180°C, typ.), then OTSD circuit starts to work. At this time, control circuit is forced to switch off all output power transistors, and drive circuit output gets into high-impedance state. TSD circuit is designed with thermal hysteresis. Only if junction temperature of drive circuit decrease to a preset temperature (120°C, typ.), can the circuit get back to normal operating condition.

5. Over-current protection (OCP)

While the IC conducts a large current, 6.0A (Typ.), the internal over-current protection function will be triggered. The device enters protection mode of auto-recover to avoid damaging IC and system.

3.5A, 3.0-25.0V H-Bridge Driver

Package ESOP8

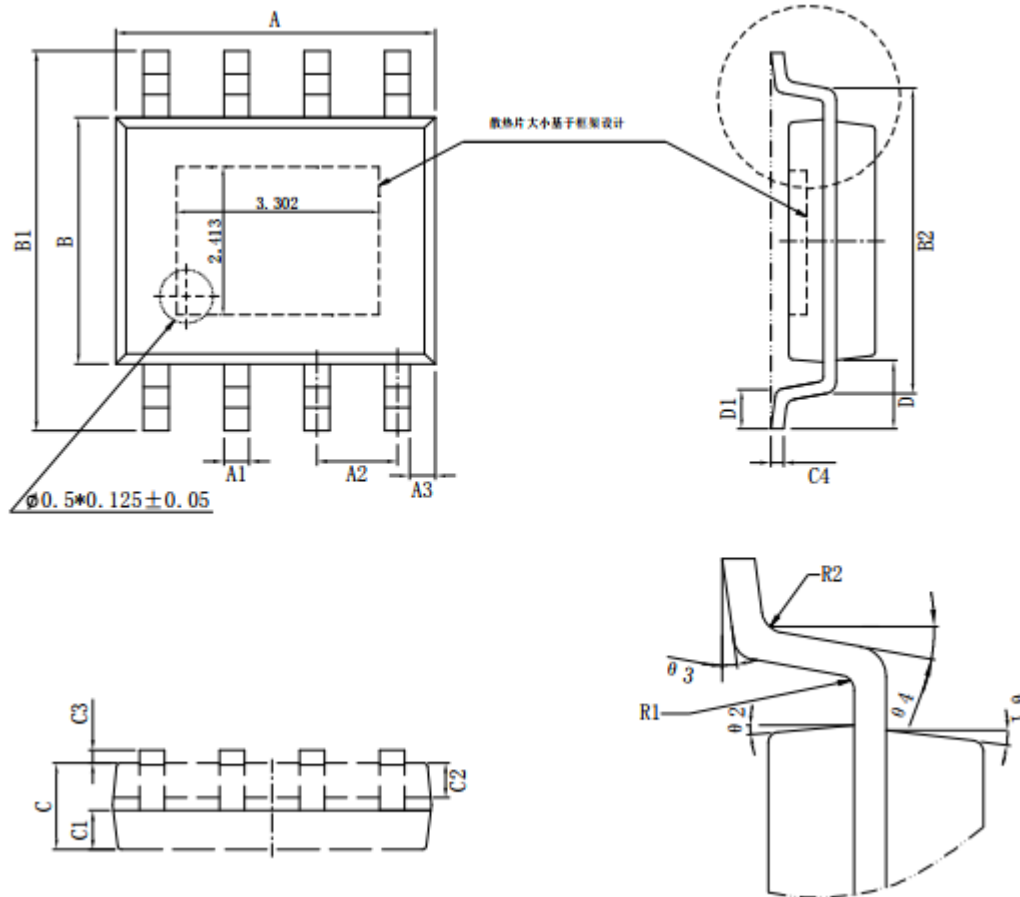

尺寸 标注	最小(mm)	最大(mm)	尺寸 标注	最小(mm)	最大(mm)
A	4.80	5.00	C3	0.00	0.09
A1	0.356	0.456	C4	0.203	0.233
A2	1.27TYP		D	1.05TYP	
A3	0.345TYP		D1	0.40	0.80
B	3.80	4.00	R1	0.20TYP	
B1	5.80	6.20	R2	0.20TYP	
B2	5.00TYP		$\theta 1$	17° TYP4	
C	1.30	1.60	$\theta 2$	13° TYP4	
C1	0.55	0.65	$\theta 3$	0° ~ 8°	
C2	0.55	0.65	$\theta 4$	4° ~ 12°	

3.5A, 3.0-25.0V H-Bridge Driver

IMPORTANT NOTICE

Syta Technology Corporation (Sytatek) reserves the right to make corrections, modifications, enhancements, improvements, and other changes to its products and to discontinue any product without notice at any time.

Sytatek cannot assume responsibility for use of any circuitry other than circuitry entirely embodied in a Sytatek product. No circuit patent licenses are implied.