

REALTEK

NOT FOR PUBLIC RELEASE

RTL8152BN-VB-CG

INTEGRATED 10/100M ETHERNET CONTROLLER FOR USB APPLICATIONS

DATASHEET

(CONFIDENTIAL: Development Partners Only)

**Rev. 1.0
08 April 2013
Track ID: JATR-8275-15**



Realtek Semiconductor Corp.
No. 2, Innovation Road II, Hsinchu Science Park, Hsinchu 300, Taiwan
Tel.: +886-3-578-0211. Fax: +886-3-577-6047

COPYRIGHT

©2013 Realtek Semiconductor Corp. All rights reserved. No part of this document may be reproduced, transmitted, transcribed, stored in a retrieval system, or translated into any language in any form or by any means without the written permission of Realtek Semiconductor Corp.

DISCLAIMER

Realtek provides this document 'as is', without warranty of any kind. Realtek may make improvements and/or changes in this document or in the product described in this document at any time. This document could include technical inaccuracies or typographical errors.

TRADEMARKS

Realtek is a trademark of Realtek Semiconductor Corporation. Other names mentioned in this document are trademarks/registered trademarks of their respective owners.

LICENSE

This product is covered by one or more of the following patents: US5,307,459, US5,434,872, US5,732,094, US6,570,884, US6,115,776, and US6,327,625.

USING THIS DOCUMENT

This document is intended for the software engineer's reference and provides detailed programming information.

Though every effort has been made to ensure that this document is current and accurate, more information may have become available subsequent to the production of this guide.

REVISION HISTORY

Revision	Release Date	Summary
1.0	2013/04/08	First release.

Table of Contents

1. GENERAL DESCRIPTION	1
2. FEATURES	3
3. SYSTEM APPLICATIONS	4
4. PIN ASSIGNMENTS	4
4.1. PACKAGE IDENTIFICATION.....	4
5. PIN DESCRIPTIONS	5
5.1. POWER MANAGEMENT PIN	5
5.2. USB INTERFACE PINS	5
5.3. TRANSCEIVER INTERFACE PINS.....	5
5.4. CLOCK PINS	6
5.5. LDO REGULATOR AND REFERENCE PINS.....	6
5.6. SPI (SERIAL PERIPHERAL INTERFACE) FLASH PINS	6
5.7. EEPROM PINS	7
5.8. LED PINS.....	7
5.9. POWER AND GROUND PINS	7
5.10. GPIO PIN.....	8
5.11. NC (NOT CONNECTED) PINS	8
6. FUNCTIONAL DESCRIPTION	9
6.1. USB INTERFACE	9
6.1.1. <i>USB Configurations</i>	9
6.1.2. <i>Endpoint 0</i>	9
6.1.3. <i>Endpoint 1 Bulk-IN</i>	9
6.1.4. <i>Endpoint 2 Bulk-OUT</i>	9
6.1.5. <i>Endpoint 3 Interrupt-IN</i>	9
6.2. CUSTOMIZABLE LED CONFIGURATION.....	10
6.2.1. <i>LED Blinking Frequency Control</i>	11
6.3. PHY TRANSCEIVER	12
6.3.1. <i>PHY Transmitter</i>	12
6.3.2. <i>PHY Receiver</i>	12
6.3.3. <i>Link Down Power Saving Mode</i>	12
6.4. SPI (SERIAL PERIPHERAL INTERFACE) FLASH.....	13
6.5. EEPROM INTERFACE.....	13
6.6. ENERGY EFFICIENT ETHERNET (EEE).....	14
6.7. LINK POWER MANAGEMENT (LPM)	14
6.8. LAN DISABLE MODE.....	14
6.9. POWER MANAGEMENT.....	15
6.10. PROTOCOL OFFLOAD	16
6.11. XTAL-LESS WAKE-ON-LAN.....	16
6.12. WAKE PACKET DETECTION (WPD)	17
6.13. ‘REAL WOW!’ (WAKE-ON-WAN) TECHNOLOGY	17
6.14. ALWAYS ON ALWAYS CONNECTED	17
6.15. LDO REGULATORS	17
7. CHARACTERISTICS	18
7.1. ABSOLUTE MAXIMUM RATINGS	18
7.2. RECOMMENDED OPERATING CONDITIONS	18
7.3. CRYSTAL REQUIREMENTS.....	19
7.4. OSCILLATOR REQUIREMENTS	19

7.5.	ENVIRONMENTAL CHARACTERISTICS	19
7.6.	DC CHARACTERISTICS.....	20
7.7.	REFLOW PROFILE RECOMMENDATIONS	20
7.8.	AC CHARACTERISTICS.....	21
7.8.1.	<i>SPI EEPROM Interface Timing</i>	21
7.8.2.	<i>TWSI EEPROM Interface Timing</i>	22
7.8.3.	<i>SPI Flash Commands</i>	24
7.8.4.	<i>SPI Flash Interface Timing Sequences</i>	24
7.8.5.	<i>SPI Flash Type Supported</i>	26
8.	MECHANICAL DIMENSIONS	27
9.	ORDERING INFORMATION	28

List of Tables

TABLE 1.	POWER MANAGEMENT PIN	5
TABLE 2.	USB INTERFACE PINS	5
TABLE 3.	TRANSCEIVER INTERFACE PINS	5
TABLE 4.	CLOCK PINS	6
TABLE 5.	LDO REGULATOR AND REFERENCE PINS	6
TABLE 6.	SPI FLASH PINS	6
TABLE 7.	EEPROM PINS	7
TABLE 8.	LED PINS.....	7
TABLE 9.	POWER AND GROUND PINS	7
TABLE 10.	GPIO PIN	8
TABLE 11.	NC (NOT CONNECTED) PINS	8
TABLE 12.	LED SELECT.....	10
TABLE 13.	CUSTOMIZED LEDES	10
TABLE 14.	LED FEATURE CONTROL-1.....	10
TABLE 15.	LED FEATURE CONTROL-2.....	10
TABLE 16.	LED OPTION 1 & OPTION 2 SETTINGS	11
TABLE 17.	LED BLINKING FREQUENCY CONTROL.....	11
TABLE 18.	SPI FLASH INTERFACE	13
TABLE 19.	EEPROM INTERFACE.....	13
TABLE 20.	ABSOLUTE MAXIMUM RATINGS	18
TABLE 21.	RECOMMENDED OPERATING CONDITIONS	18
TABLE 22.	CRYSTAL REQUIREMENTS.....	19
TABLE 23.	OSCILLATOR REQUIREMENTS	19
TABLE 24.	ENVIRONMENTAL CHARACTERISTICS	19
TABLE 25.	DC CHARACTERISTICS.....	20
TABLE 26.	REFLOW PROFILE RECOMMENDATIONS	20
TABLE 27.	SPI EEPROM ACCESS TIMING PARAMETERS.....	21
TABLE 28.	TWSI EEPROM ACCESS TIMING PARAMETERS.....	23
TABLE 29.	SPI FLASH COMMANDS.....	24
TABLE 30.	SPI FLASH TYPE SUPPORTED.....	26
TABLE 31.	ORDERING INFORMATION	28

List of Figures

FIGURE 1.	PIN ASSIGNMENTS	4
FIGURE 2.	LED BLINKING FREQUENCY AND DUTY CYCLE.....	11
FIGURE 3.	SPI EEPROM INTERFACE TIMING	21
FIGURE 4.	TWSI EEPROM INTERFACE TIMING-1	22
FIGURE 5.	TWSI EEPROM INTERFACE TIMING-2	22
FIGURE 6.	TWSI EEPROM INTERFACE TIMING-3	23
FIGURE 7.	TWSI EEPROM INTERFACE TIMING-4	23
FIGURE 8.	WREN/WRDI TIMING SEQUENCE	24
FIGURE 9.	READ TIMING SEQUENCE	24
FIGURE 10.	PAGE PROGRAM TIMING SEQUENCE	25
FIGURE 11.	SECTOR/BLOCK ERASE TIMING SEQUENCE.....	25
FIGURE 12.	CHIP ERASE TIMING SEQUENCE.....	25

1. General Description

The Realtek RTL8152BN-VB-CG 10/100M Ethernet controller combines an IEEE 802.3u compliant Media Access Controller (MAC), USB bus controller, and embedded memory. A linear regulator (LDO) is incorporated for reduced BOM cost.

With state-of-the-art DSP technology and mixed-mode signal technology, the RTL8152BN-VB offers high-speed transmission over CAT 5 UTP cable or CAT 3 UTP (10Mbps only) cable. Functions such as Crossover Detection and Auto-Correction, polarity correction, adaptive equalization, cross-talk cancellation, echo cancellation, timing recovery, and error correction are implemented to provide robust transmission and reception capabilities. The RTL8152BN-VB features embedded One-Time-Programmable (OTP) memory to replace the external EEPROM (93C46/93C56/93C66/TWSI).

Advanced Configuration Power management Interface (ACPI)—power management for modern operating systems that are capable of Operating System-directed Power Management (OSPM)—is supported to achieve the most efficient power management possible. In addition to the ACPI feature, remote wake-up (including AMD Magic Packet and Microsoft Wake-Up Frame) is supported in both ACPI and APM (Advanced Power Management) environments.

The RTL8152BN-VB supports Microsoft Wake Packet Detection (WPD) to provide Wake-Up Frame information to the OS, e.g., PatternID, OriginalPacketSize, SavedPacketSize, SavedPacketOffset, etc. WPD helps prevent unwanted/unauthorized wake-up of a sleeping computer.

The RTL8152BN-VB supports ‘RealWoW!’ Technology which enables remote wake-up of a sleeping PC through the Internet. This feature allows PCs to reduce power consumption by remaining in low power sleeping state until needed.

Note: The ‘RealWoW!’ service requires registration on first time use.

The RTL8152BN-VB is fully compliant with Microsoft NDIS5, NDIS6 (IPv4, IPv6, TCP, UDP) Checksum features, and supports IEEE 802 IP Layer 2 priority encoding and IEEE 802.1Q Virtual bridged Local Area Network (VLAN). The above features contribute to lowering CPU utilization, especially benefiting performance when in operation on a network server.

The RTL8152BN-VB supports Protocol offload. It offloads some of the most common protocols to NIC hardware in order to prevent spurious wake-up and further reduce power consumption. The RTL8152BN-VB can offload ARP (IPv4) and NS (IPv6) protocols while in the D3 power saving state.

The RTL8152BN-VB supports the ECMA (European Computer Manufacturers Association) proxy for sleeping hosts standard. The standard specifies maintenance of network connectivity and presence via proxies in order to extend the sleep duration of higher-powered hosts. It handles some network tasks on behalf of the host, allowing the host to remain in sleep mode for longer periods. Required and optional behavior of an operating proxy includes generating reply packets, ignoring packets, and waking the host.

The RTL8152BN-VB supports IEEE 802.3az-2010, also known as Energy Efficient Ethernet (EEE). IEEE 802.3az operates with the IEEE 802.3 Media Access Control (MAC) Sublayer to support operation in Low Power Idle mode. When the Ethernet network is in low link utilization, EEE allows systems on both sides of the link to save power.

The device also features USB 2.0 technology. It provides higher bandwidth and improved protocols for data exchange between the host and the device. In addition, USB 2.0 offers a more aggressive power management feature that enables selective suspend to save energy.

The RTL8152BN-VB is suitable for multiple market segments and emerging applications, such as desktop, mobile, workstation, server, communications platforms, docking station, and embedded applications.

2. Features

Hardware

- Integrated 10/100M transceiver
- Auto-Negotiation with Next Page capability
- Supports USB 2.0 and 1.1
- Supports pair swap/polarity/skew correction
- Crossover Detection & Auto-Correction
- Supports Wake-On-LAN and ‘RealWoW!’ (Wake-On-WAN) Technology (see note 1)
- Supports ECMA-393 ECMA ProxZzzy Standard for sleeping hosts (see note 1)
- XTAL-Less Wake-On-LAN
- Supports 25MHz or 48MHz external clock (from oscillator or system clock source)
- Supports power down/link down power saving
- Transmit/Receive on-chip buffer support
- Embedded OTP memory
- Built-in linear regulator (LDO)
- Supports Customizable LEDs
- Controllable LED Blinking Frequency and Duty Cycle
- Supports hardware CRC (Cyclic Redundancy Check) function
- LAN disable with GPIO pin
- Supports LPM (Link Power Management)
- SPI Flash Interface
- Serial EEPROM
- Supports CDC-ECM

- 48-pin QFN ‘Green’ package

Software Offload

- Microsoft NDIS5, NDIS6 Checksum Offload (IPv4, IPv6, TCP, UDP) and Segmentation Task-offload (Large send v1 and Large send v2) support

IEEE

- Supports Full Duplex flow control (IEEE 802.3x)
- Fully compliant with IEEE 802.3, IEEE 802.3u
- Supports IEEE 802.1P Layer 2 Priority Encoding
- Supports IEEE 802.1Q VLAN tagging
- Supports IEEE 802.3az-2010 (EEE)

Microsoft AOAC (Always On Always Connected)

- Supports 16-set 128-byte Wake-Up Frame pattern exact matching
- Supports link change wake up
- Supports Microsoft WPD (Wake Packet Detection)
- Supports Protocol Offload (ARP & NS)

Intel CPPM (Converged Platform Power Management)

- Supports L1 with 3ms BESL
- Supports selective suspend

Note 1. Select between RealWoW! or ECMA; only one feature can be active at a time.

3. System Applications

- USB 10/100M Ethernet on Motherboard, Dongle, Notebook, Docking station, or Embedded system

4. Pin Assignments

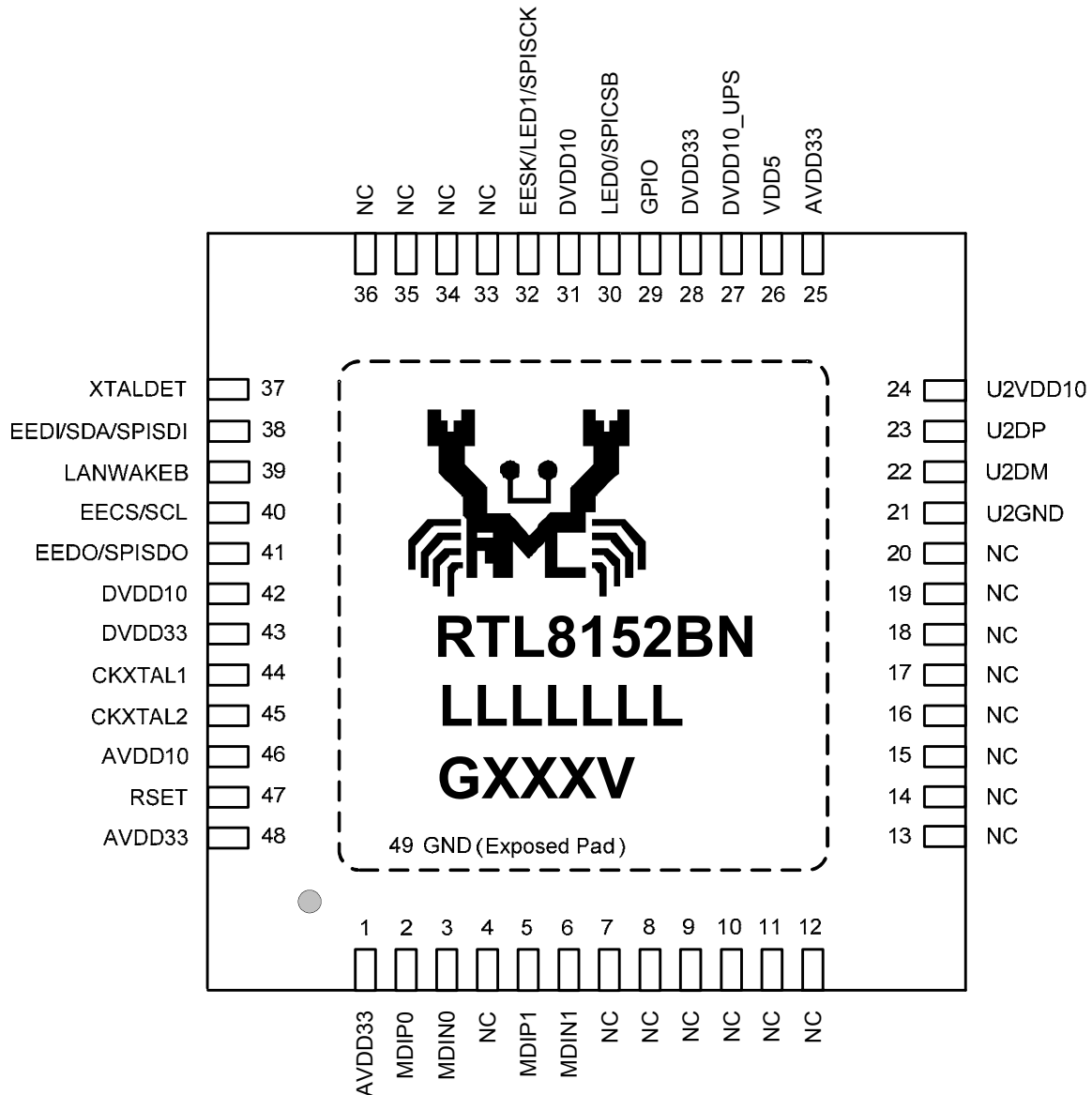

Figure 1. Pin Assignments

4.1. Package Identification

Green package is indicated by the ‘G’ in GXXXV (Figure 1). The version number is indicated by the ‘V’.

5. Pin Descriptions

The signal type codes below are used in the following tables:

I: Input

O: Output

P: Power

5.1. Power Management Pin

Table 1. Power Management Pin

Symbol	Type	Pin No	Description
LANWAKEB	O	39	Power Management Event Output Pin (Active Low), minimum 7ms, maximum 9ms.

5.2. USB Interface Pins

Table 2. USB Interface Pins

Symbol	Type	Pin No	Description
U2DP	IO	23	USB 2.0/USB 1.1 Differential Signal Pair.
U2DM	IO	22	

5.3. Transceiver Interface Pins

Table 3. Transceiver Interface Pins

Symbol	Type	Pin No	Description
MDIP0	IO	2	In MDI mode, this pair acts as the BI_DA+/- pair, and is the transmit pair in 10Base-T and 100Base-TX.
MDIN0	IO	3	In MDI crossover mode, this pair acts as the BI_DB+/- pair, and is the receive pair in 10Base-T and 100Base-TX.
MDIP1	IO	5	In MDI mode, this pair acts as the BI_DB+/- pair, and is the receive pair in 10Base-T and 100Base-TX.
MDIN1	IO	6	In MDI crossover mode, this pair acts as the BI_DA+/- pair, and is the transmit pair in 10Base-T and 100Base-TX.

5.4. Clock Pins

Table 4. Clock Pins

Symbol	Type	Pin No	Description
CKXTAL1	I	44	Input of 25MHz Clock Reference.
CKXTAL2	IO	45	Output of 25MHz Clock Reference. Input of 25MHz or 48MHz External Clock Source.
XTALDET	I	37	Power-Up Strapping Pin. Power-on latch high voltage: 25MHz clock source Power-on latch low voltage: 48MHz clock source

Note: When a 25MHz clock is used, the XTALDET pin must be pulled high by a resistor during power-up. When a 48MHz clock is used, the XTALDET pin must be pulled low by a resistor during power-up.

5.5. LDO Regulator and Reference Pins

Table 5. LDO Regulator and Reference Pins

Symbol	Type	Pin No	Description
AVDD33	P	25	Linear Regulator (LDO) 3.3V Output. <i>Note: The embedded LDO is designed for RTL8152BN-VB internal use only. Do not provide this power source to other devices.</i>
AVDD10	P	46	Linear Regulator (LDO) 1.05V Output. <i>Note: The embedded LDO is designed for RTL8152BN-VB internal use only. Do not provide this power source to other devices.</i>
DVDD10_UPS	P	27	Linear Regulator (LDO) 1.05V Output. <i>Note: The embedded LDO is designed for RTL8152BN-VB internal use only. Do not provide this power source to other devices.</i>
RSET	I	47	Reference (External Resistor Reference).

5.6. SPI (Serial Peripheral Interface) Flash Pins

Table 6. SPI Flash Pins

Symbol	Type	Pin No	Description
SPICSB	O	30	SPI Flash Chip Select.
SPISDO	I	41	Input from SPI Flash Serial Data Output Pin.
SPISDI	O	38	Output to SPI Flash Serial Data Input Pin.
SPISCK	O	32	SPI Flash Serial Data Clock.

5.7. EEPROM Pins

Table 7. EEPROM Pins

Symbol	Type	Pin No	Description
EESK	O	32	Serial Data Clock for 93C46/93C56/93C66.
EEDI/SDA	IO	38	EEDI: Output to serial data input pin of EEPROM (93C46/93C56/93C66) SDA: Data interface for TWSI EEPROM Refer to the reference schematic for strapping pin information. All strapping pins are power-on latch pins. Power-on latch high voltage: TWSI EEPROM Power-on latch low voltage: SPI EEPROM
EEDO	I	41	Input from Serial Data Output Pin of EEPROM (93C46/93C56/93C66). Refer to the reference schematic for strapping pin information. All strapping pins are power-on latch pins. Power-on latch high voltage: 93C46 Power-on latch low voltage: 93C56/93C66
EECS/SCL	O	40	EECS: EEPROM (93C46/93C56/93C66) Chip Select SCL: Serial Data Clock for TWSI EEPROM

5.8. LED Pins

Table 8. LED Pins

Symbol	Type	Pin No	Description
LED0	O	30	See Section 6.2 Customizable LED Configuration, Page 10 for Details.
LED1	O	32	

Note: During power down mode, the LED signals are logic high.

5.9. Power and Ground Pins

Table 9. Power and Ground Pins

Symbol	Type	Pin No	Description
VDD5	P	26	Analog 5.0V Power Supply.
AVDD33	P	1, 25, 48	Analog 3.3V Power Supply.
DVDD33	P	28, 43	Digital 3.3V Power Supply.
AVDD10	P	46	Analog 1.05V Power Supply.
DVDD10	P	31, 42	Digital 1.05V Power Supply.
DVDD10_UPS	P	27	Digital 1.05V Uninterruptible Power Supply.
U2VDD10	P	24	USB 2.0/USB 1.1 Digital 1.05V Power Supply.
U2GND	P	21	USB 2.0/USB 1.1 Ground.
GND	P	49	Ground (Exposed Pad).

Note: Refer to the latest schematic circuit for correct configuration.

5.10. GPIO Pin

Table 10. GPIO Pin

Symbol	Type	Pin No	Description
GPIO	IO	29	General Purpose Input/Output Pin. Link OK Feature: Output Pin (Active High) Power Saving Feature: Output Pin (Active Low) LAN Disable Mode: Input Pin (Active Low)

5.11. NC (Not Connected) Pins

Table 11. NC (Not Connected) Pins

Symbol	Type	Pin No	Description
NC	-	4, 7, 8, 9, 10, 11, 12, 13, 14, 15, 16, 17, 18, 19, 20, 33, 34, 35, 36	Not Connected.

6. Functional Description

6.1. USB Interface

The SIE (Serial Interface Engine) employs a robust hardwired USB protocol implementation so that the entire USB interface operation can be done without firmware intervention. For all three types of End Points (Bulk-IN, Bulk-OUT, and Interrupt-IN), appropriate responses and handshake signals are generated by the SIE. The SIE analog transceiver complies fully with driver and receiver characteristics defined in USB Specification Rev. 2.0.

6.1.1. USB Configurations

The RTL8152BN-VB supports two networking configurations, ECM (Ethernet Networking Control Model) configuration, and in-house configuration. The ECM configuration complies with CDC-ECM, and is a general Ethernet networking model that enables network communication without installing additional vendor specific drivers. The in-house configuration requires a vendor specific driver to support enhanced features and optimized performance.

6.1.2. Endpoint 0

All USB devices support a common access mechanism for accessing information through this control pipe. Associated with the control pipe at endpoint 0 is the information required to completely describe the USB device. This pipe also provides the register read and write to the RTL8152BN-VB.

6.1.3. Endpoint 1 Bulk-IN

The maximum Bulk-IN packet size is 512 bytes. Each Ethernet packet is transferred to the HOST by this Endpoint. If the Ethernet packet is larger than 512 bytes, the RTL8152BN-VB splits the Ethernet packet into multiples of 512 bytes. The HOST treats USB packets that are less than 512 bytes or are equal to zero as End of Ethernet packets.

6.1.4. Endpoint 2 Bulk-OUT

The HOST sends the USB packet to Ethernet. If the Ethernet packet is larger than 512 bytes, the Host will send the Ethernet packet in multiples of 512 bytes. A USB packet that is less than 512 bytes or is equal to zero is treated as an End of Ethernet packet.

The Ethernet packet (containing multiple USB packets) will be queued in the TX FIFO and transmitted when possible. If the Ethernet packet is transmitted without error, the TX FIFO space that was occupied by the transmitted Ethernet packet will be released. If the 2K TX FIFO is full, the RTL8152BN-VB will respond with a NYET when the host tries to Bulk-OUT more USB packets.

It is possible to have multiple Ethernet packets in the TX FIFO simultaneously. If an Ethernet packet is to be transmitted but experiences collisions more than 16 times (default), this is called a transmit abort and the packet will be skipped for transmission by the RTL8152BN-VB.

6.1.5. Endpoint 3 Interrupt-IN

The Interrupt Endpoint (EP3) can be used to poll the current link speed and link ok status of the RTL8152BN-VB.

6.2. Customizable LED Configuration

The RTL8152BN-VB supports customizable LED operation modes via OCP register offset 0xDD90h. Table 12 describes the different LED actions.

Table 12. LED Select

Bit	Symbol	RW	Description
7:4	LEDSEL1	RW	LED Select for PINLED1.
3:0	LEDSEL0	RW	LED Select for PINLED0.

Configure OCP register offset 0xDD90h to support your own LED signals. For example, if the value in the OCP offset 0xDD90 is 0xA1h (10100001b), the LED actions are:

- LED 0: On only in 10M mode, with no blinking during TX/RX
- LED 1: On only in 100M mode, with TX/RX blinking

Table 13. Customized LEDs

	LINK		ACT
Speed	Link 10M	Link 100M	-
LED 0	Bit 0	Bit 1	Bit 3
LED 1	Bit 4	Bit 5	Bit 7

Table 14. LED Feature Control-1

Feature Control	Bit12	Bit13	Bit14	Bit15
0	LED0 Low Active	LED1 Low Active	RSVD	Indicates Option 1 of Table 16 is Selected
1	LED0 High Active	LED1 High Active	RSVD	Indicates Option 2 of Table 16 is Selected

Table 15. LED Feature Control-2

LED Pin	ACT=0	ACT=1
LINK=0	Floating	All Speed ACT
LINK>0	Selected Speed LINK	Option 1 (see Table 16): Selected Speed LINK+ Selected Speed ACT Option 2 (see Table 16): Selected Speed LINK+ All Speed ACT

Note 1: ACT means blinking TX and RX. LINK indicates Link 10M and Link 100M.

Note 2: There is a special mode: LED OFF Mode → Set all bits to 0.

Table 16. LED Option 1 & Option 2 Settings

Link Bit		Active Bit	Description		
10	100		Link	Option 1 LED Activity	Option 2 LED Activity
0	0	0	LED Off		
0	0	1	-	Act ₁₀ +Act ₁₀₀	Act ₁₀ +Act ₁₀₀
0	1	0	Link ₁₀₀	-	-
0	1	1	Link ₁₀₀	Act ₁₀₀	Act ₁₀ +Act ₁₀₀
1	0	0	Link ₁₀	-	-
1	0	1	Link ₁₀	Act ₁₀	Act ₁₀ +Act ₁₀₀
1	1	0	Link ₁₀ +Link ₁₀₀	-	-
1	1	1	Link ₁₀ +Link ₁₀₀	Act ₁₀ +Act ₁₀₀	Act ₁₀ +Act ₁₀₀

Note:

Act₁₀ = LED blinking when Ethernet packets transmitted/received at 10Mbps.

Act₁₀₀ = LED blinking when Ethernet packets transmitted/received at 100Mbps.

Link₁₀ = LED lit when Ethernet connection established at 10Mbps.

Link₁₀₀ = LED lit when Ethernet connection established at 100Mbps.

6.2.1. LED Blinking Frequency Control

The RTL8152BN-VB also supports LED blinking frequency and duty cycle control via OCP register offset DD92h to control user's LED blinking frequency and duty cycle (see Table 17). For example, if the OCP register offset 0xDD92 is 0x0B (00001011b), the LED blinking frequency is 80ms and duty cycle is 75%. The LED state is shown in Figure 2.

Table 17. LED Blinking Frequency Control

Bit	RW	Description
3:2	RW	LED Blinking Frequency. 0: 240ms 1: 160ms (Default) 2: 80ms 3: Link Speed Dependent
1:0	RW	LED Blinking Duty Cycle. 0: 12.5% 1: 25% 2: 50% (Default) 3: 75%

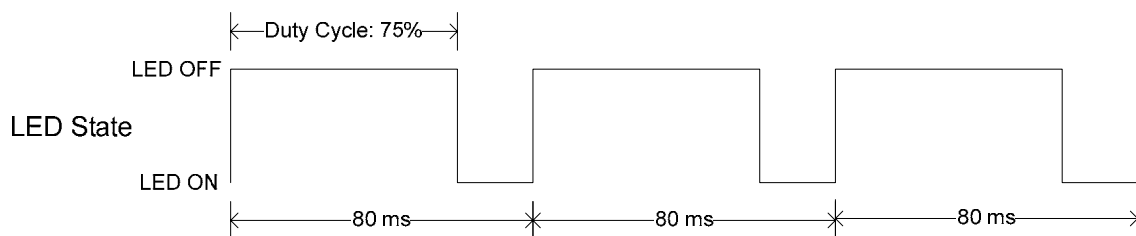

Note: Assumes the LED is low active.

Figure 2. LED Blinking Frequency and Duty Cycle

6.3. PHY Transceiver

Based on state-of-the-art DSP technology and mixed-mode signal processing technology, the RTL8152BN-VB operates at 10/100Mbps over standard CAT.5 UTP cable (100Mbps), and CAT.3 UTP cable (10Mbps).

6.3.1. PHY Transmitter

MII (100Mbps) Mode

The transmitted 4-bit nibbles (TXD[3:0]) from the MAC, clocked at 25MHz (TXC), are converted into 5B symbol code through 4B/5B coding technology, then through scrambling and serializing, are converted to 125MHz NRZ and NRZI signals. The NRZI signals are passed to the MLT3 encoder, then to the D/A converter and transmitted onto the media.

MII (10Mbps) Mode

The transmitted 4-bit nibbles (TXD[3:0]) from the MAC, clocked at 2.5MHz (TXC), are serialized into 10Mbps serial data. The 10Mbps serial data is converted into a Manchester-encoded data stream and is transmitted onto the media by the D/A converter.

6.3.2. PHY Receiver

MII (100Mbps) Mode

The MLT3 signal is processed with an ADC, equalizer, BLW (Baseline Wander) correction, timing recovery, MLT3 and NRZI decoder, descrambler, 4B/5B decoder, and is then presented to the MII interface in 4-bit-wide nibbles at a clock speed of 25MHz.

MII (10Mbps) Mode

The received differential signal is converted into a Manchester-encoded stream first. The stream is processed with a Manchester decoder and is de-serialized into 4-bit-wide nibbles. The 4-bit nibbles are presented to the MII interface at a clock speed of 2.5MHz.

6.3.3. Link Down Power Saving Mode

The RTL8152BN-VB implements link down power saving mode, greatly improving power consumption when the network cable is disconnected. The RTL8152BN-VB automatically enters link down power saving mode within three seconds after the cable is disconnected from it. Once it enters link down power saving mode, it transmits normal link pulses on its TX pins and continues to monitor the RX pins to detect incoming signals. After it detects an incoming signal, it wakes up from link down power saving mode and operates in normal mode according to the result of the connection.

6.4. SPI (Serial Peripheral Interface) Flash

SPI Flash is enabled by the RTL8152BN-VB through the Chip Select pin, and accessed via a 3-wire interface consisting of Serial Data Input (SI), Serial Data Output (SO), and Serial Clock (SCK). The SPI flash utilizes an 8-bit instruction register. All instructions, addresses, and data are transferred with the MSB first and start with a high-to-low transition.

Compared to a parallel bus interface, the Serial Peripheral Interface provides simpler wiring and much less interaction (crosstalk) among the conductors in the cable. This minimizes the number of conductors, pins, and the IC package size, reducing the cost of making, assembling, and testing the electronics.

Table 18. SPI Flash Interface

SPI Flash	Description
SO	Input Data Bus.
SI	Output Data Bus.
SCK	SPI Flash Serial Data Clock.
CS	SPI Flash Chip Select.

6.5. EEPROM Interface

Both SPI and TWSI EEPROM interfaces are supported. The SPI interface utilizes a 93C46/93C56/93C66, which is a 1K-bit/2K-bit/4K-bit, respectively, EEPROM. The EEPROM interface permits the RTL8152BN-VB to read from, and write data to, an external serial EEPROM device.

Values in the internal eFUSE memory or external EEPROM allow default register values to be overridden following a power-on or software EEPROM auto-load command. The RTL8152BN-VB will auto-load values from the eFUSE or EEPROM. If the EEPROM is not present and eFUSE auto-load is bypassed, the RTL8152BN-VB initialization uses default values for the appropriate Configuration and Operational Registers. Software can read and write to the EEPROM using bit-bang accesses via the 9346CR Register. The EEPROM SPI interface consists of EESK, EECS, EEDO, and EEDI. The TWSI interface shares SCL/SDA with EECS/EEDI.

The correct EEPROM (i.e., 93C46/93C56/93C66) must be used in order to ensure proper LAN function.

Table 19. EEPROM Interface

EEPROM	Description
EECS/SCL	EECS: EEPROM (93C46/93C56/93C66) chip select SCL: Serial data clock for TWSI EEPROM
EESK	Serial Data Clock for EEPROM (93C46/93C56/93C66).
EEDI/SDA	EEDI: Output to serial data input pin of EEPROM (93C46/93C56/93C66) SDA: Data interface for TWSI EEPROM
EEDO	Input from Serial Data Output Pin of EEPROM (93C46/93C56/93C66).

6.6. Energy Efficient Ethernet (EEE)

The RTL8152BN-VB supports IEEE 802.3az-2010, also known as Energy Efficient Ethernet (EEE), at 10Mbps and 100Mbps. It provides a protocol to coordinate transitions to/from a lower power consumption level (Low Power Idle mode) based on link utilization. When no packets are being transmitted, the system goes to Low Power Idle mode to save power. Once packets need to be transmitted, the system returns to normal mode, and does this without changing the link status and without dropping/corrupting frames.

To save power, when the system is in Low Power Idle mode, most of the circuits are disabled, however, the transition time to/from Low Power Idle mode is kept small enough to be transparent to upper layer protocols and applications.

EEE also specifies a negotiation method to enable link partners to determine whether EEE is supported and to select the best set of parameters common to both devices.

Refer to <http://www.ieee802.org/3/az/index.html> for more details.

6.7. Link Power Management (LPM)

The RTL8152BN-VB supports Link Power Management (LPM). It provides an efficient way to manage bus and system power via hosts and hubs. It implements a power sleep state that reduces power consumption by providing faster suspend and resume times. The four power management states for USB are L0 (On), L1 (Sleep), L2 (Suspend) and L3 (Off). To reduce power consumption when the system is in Low Power State, some of the circuits are disabled.

Refer to <http://www.usb.org/developers/docs/>.

6.8. LAN Disable Mode

The RTL8152BN-VB supports ‘LAN Disable Mode’, which uses an external signal to control whether the NIC is enabled or disabled.

6.9. Power Management

The RTL8152BN-VB complies with ACPI (Rev 1.0, 1.0b, 2.0), Network Device Class Power Management Reference Specification (V1.0a), such as to support an Operating System-directed Power Management (OSPM) environment.

The RTL8152BN-VB can monitor the network for a Wake-Up Frame or a Magic Packet, and notify the system via the USB interface when such a packet or event occurs. The system is then restored to a normal state to process incoming jobs.

When the RTL8152BN-VB is in power down mode:

- The RX state machine is stopped. The RTL8152BN-VB monitors the network for wake-up events such as a Magic Packet and Wake-Up Frame in order to wake up the system. When in power down mode, the RTL8152BN-VB will not reflect the status of any incoming packets in the ISR register and will not receive any packets into the RX on-chip buffer.
- The on-chip buffer status and packets that have already been received into the RX on-chip buffer before entering power down mode are held by the RTL8152BN-VB.
- Transmission is stopped. USB transactions are stopped. The TX on-chip buffer is held.
- After being restored to D0 state, the RTL8152BN-VB transmits data that was not moved into the TX on-chip buffer during power down mode. Packets that were not transmitted completely last time are re-transmitted.

Magic Packet Wake-Up occurs only when the following conditions are met:

- The destination address of the received Magic Packet is acceptable to the RTL8152BN-VB, e.g., a broadcast, multicast, or unicast packet addressed to the current RTL8152BN-VB adapter.
- The received Magic Packet does not contain a CRC error.
- The Magic Packet pattern matches, i.e., $6 * FFh + MISC$ (can be none) + $16 * DID$ (Destination ID) in any part of a valid Ethernet packet.

A Wake-Up Frame event occurs only when the following conditions are met:

- The destination address of the received Wake-Up Frame is acceptable to the RTL8152BN-VB, e.g., a broadcast, multicast, or unicast address to the current RTL8152BN-VB adapter.
- The received Wake-Up Frame does not contain a CRC error.
- The 16-bit CRC of the received Wake-Up Frame matches the 16-bit CRC of the sample Wake-Up Frame pattern given by the local machine's OS. Or, the RTL8152BN-VB is configured to allow direct packet wake-up, e.g., a broadcast, multicast, or unicast network packet.
- The 128-byte of the received Wake-Up Frame matches the 128-byte of the sample Wake-Up Frame pattern given by the local machine's OS.

Note 1: 16-bit CRC: The RTL8152BN-VB supports 16-set 16-bit CRC wake-up frames (covering 128 mask bytes from offset 0 to 127 of any incoming network packet). CRC16 polynomial= $x^{16}+x^{12}+x^5+1$.

Note 2: 128-byte Wake-Up Frame: The RTL8152BN-VB supports 16-set 128-byte wake-up frames. If enabled, the 16-bit CRC wake-up match will be disabled.

6.10. Protocol Offload

Protocol offload is a task offload supported by Microsoft Windows 7. It maintains a network presence for a sleeping higher power host. Protocol offload prevents spurious wake-up and further reduces power consumption. It maintains connectivity while hosts are asleep, including receiving requests from other nodes on the network, ignoring packets, generating packets while in the sleep state (e.g., the Ethernet Controller will generate ARP responses if the same MAC and IPv4 address are provided in the configuration data), and intelligently wake-up host systems. The RTL8152BN-VB supports the ECMA (European Computer Manufacturers Association) specification including proxy configuration and management, IPv4 ARP, IPv6 NDP, and wake-up packets. The RTL8152BN-VB also supports optional ECMA items such as QoS tagged packets and duplicate address detection.

6.11. XTAL-Less Wake-On-LAN

The RTL8152BN-VB supports board level design with an external 25MHz or 48MHz clock source instead of the crystal.

The external clock source may stop generating the clock when in suspend mode (S3/S4/S5). To support the Wake-On-LAN function without the external clock source, the RTL8152BN-VB will automatically change its source clock from the external clock to an internal self-oscillating auxiliary clock when it enters suspend mode. Note that when in suspend mode, the auxiliary clock can establish only a 10Mbps link and does not support ARP/NS offload and ECMA ProxZzzy.

6.12. Wake Packet Detection (WPD)

The RTL8152BN-VB supports Microsoft Wake Packet Detection (WPD) to provide Wake-Up Frame information to the OS, e.g., PatternID, OriginalPacketSize, SavedPacketSize, SavedPacketOffset, etc. WPD helps prevent unwanted/unauthorized wake-up of a sleeping computer.

Refer to the Microsoft Wake Packet Detection (WPD) Interface Specification for details ([http://msdn.microsoft.com/en-us/library/hh440160\(v=vs.85\).aspx](http://msdn.microsoft.com/en-us/library/hh440160(v=vs.85).aspx)).

6.13. 'RealWoW!' (Wake-On-WAN) Technology



The RTL8152BN-VB supports Realtek 'RealWoW!' technology that allows the RTL8152BN-VB to send keep alive packets to the Wake Server when the PC is in sleeping mode. Realtek 'RealWoW!' can pass wake-up packets through a NAT (Network Address Translation) device. This feature allows PCs to reduce power consumption by remaining in low power sleeping state until needed.

Users can login into the Wake Server via the Internet to wake the selected sleeping PC. Registration of Account information to the Wake Server is required on first time use.

6.14. Always On Always Connected

The RTL8152BN-VB supports Microsoft's AOAC (Always On Always Connected) model. The AOAC platform can enter the system state 'Connected Standby' and allow the RTL8152BN-VB to enter a low-power state. The RTL8152BN-VB will maintain Layer 2 connectivity and generate a wake signal when one of the following conditions is satisfied:

- Link status becomes 'connected'
- Link status becomes 'disconnected'
- Receives a WOL pattern
- Receives a wildcard pattern

6.15. LDO Regulators

The RTL8152BN-VB incorporates three linear Low-Dropout (LDO) regulators that feature high power supply ripple rejection and low output noise. The RTL8152BN-VB embedded LDO regulators do not require power inductors on the PCB; only an output capacitor between its output and analog ground for phase compensation, which saves cost and PCB real estate.

The output capacitors (and bypass capacitors) should be placed as close as possible to the power pins for adequate filtering.

Note 1: The embedded LDO is designed for RTL8152BN-VB internal use only. Do not provide this power source to other devices.

Note 2: The LDO 1.05V output pin (DVDD10_UPS) must be separated from the other LDO 1.05V output pin (AVDD10).

7. Characteristics

7.1. Absolute Maximum Ratings

WARNING: Absolute maximum ratings are limits beyond which permanent damage may be caused to the device, or device reliability will be affected. All voltages are specified reference to GND unless otherwise specified.

Table 20. Absolute Maximum Ratings

Symbol	Description	Minimum	Maximum	Unit
VDD5IN	Supply Voltage 5.0V	-0.3	5.5	V
VDD33OUT, AVDD33, DVDD33	Supply Voltage 3.3V	-0.3	3.63	V
AVDD10, DVDD10, DVDD10_UPS	Supply Voltage 1.05V	-0.3	1.32	V
Dcinput	Input Voltage	-0.3	Corresponding Supply Voltage + 10%	V
Dcoutput	Output Voltage	-0.3	Corresponding Supply Voltage + 10%	V
N/A	Storage Temperature	-55	+125	°C

Note: Refer to the latest schematic circuit for correct configuration.

7.2. Recommended Operating Conditions

Table 21. Recommended Operating Conditions

Description	Symbol	Minimum	Typical	Maximum	Unit
Supply Voltage VDD	VDD5	4.75	5.0	5.25	V
	AVDD33, DVDD33	3.14	3.3	3.46	V
	AVDD10, DVDD10, DVDD10_UPS	1.0	1.05	1.1	V
Ambient Operating Temperature T_A	-	0	-	70	°C
Maximum Junction Temperature	-	-	-	125	°C

Note: Refer to the latest schematic circuit for correct configuration.

7.3. Crystal Requirements

Table 22. Crystal Requirements

Symbol	Description/Condition	Minimum	Typical	Maximum	Unit
F _{ref}	Parallel resonant crystal reference frequency, fundamental mode, AT-cut type.	-	25/48	-	MHz
F _{ref} Stability	Parallel resonant crystal frequency stability, fundamental mode, AT-cut type. T _a = 0°C ~ +70°C.	-30	-	+30	ppm
F _{ref} Tolerance	Parallel resonant crystal frequency tolerance, fundamental mode, AT-cut type. T _a = 25°C.	-50	-	+50	ppm
F _{ref} Duty Cycle	Reference Clock Input Duty Cycle.	40	-	60	%
ESR	Equivalent Series Resistance.	-	-	70	Ω
CL	Load Capacitance.	16	-	20	pF
DL	Drive Level.	-	-	0.5	mW

Note 1: The CLK source can come from other places in the system, but it must accord with the parameters above.

Note 2: Broadband RMS=9ps; 25KHz to 25MHz RMS=3ps.

Note 3: The ESR maximum value of 70ohm is based on shunt capacitance (Co) less than 7pF.

Note 4: The accuracy of the crystal resonance frequency can be achieved by matching the load capacitance correctly to the designed-in circuit. The latest schematic circuit recommends two external capacitors of 27pF connected between the crystal and ground. To match this use the load capacitance specified by the crystal manufacturer of 16~20pF.

7.4. Oscillator Requirements

Table 23. Oscillator Requirements

Parameter	Condition	Minimum	Typical	Maximum	Unit
Frequency	-	-	25/48	-	MHz
Frequency Stability	T _a = 0°C~+70°C	-30	-	+30	ppm
Frequency Tolerance	T _a = 25°C	-50	-	+50	ppm
Duty Cycle	-	40	-	60	%
Broadband Peak-to-Peak Jitter	-	-	-	200	ps
V _{p-p}	-	3.15	3.3	3.45	V
Rise Time	-	-	-	10	ns
Fall Time	-	-	-	10	ns
Operation Temp Range	-	0	-	70	°C

Note 1: The CLK source can come from other places in the system, but it must accord with the parameters above.

Note 2: Broadband RMS=9ps; 25KHz to 25MHz RMS=3ps.

7.5. Environmental Characteristics

Table 24. Environmental Characteristics

Parameter	Minimum	Maximum	Units
Storage Temperature	-55	+125	°C
Ambient Operating Temperature	0	70	°C

7.6. DC Characteristics

Table 25. DC Characteristics

Symbol	Parameter	Conditions	Minimum	Typical	Maximum	Units
VDD5	5.0V Supply Voltage	-	4.75	5.00	5.25	V
AVDD33, DVDD33	3.3V Supply Voltage	-	3.14	3.30	3.46	V
AVDD10, DVDD10, DVDD10_UPS	1.05V Supply Voltage	-	1.00	1.05	1.10	V
V _{oh}	Minimum High Level Output Voltage	I _{oh} = -4mA	0.9*VDD33	-	VDD33	V
V _{ol}	Maximum Low Level Output Voltage	I _{ol} = 4mA	0	-	0.1*VDD33	V
V _{ih}	Minimum High Level Input Voltage	-	2.0	-	-	V
V _{il}	Maximum Low Level Input Voltage	-	-	-	0.8	V
I _{in}	Input Current	V _{in} = VDD33 or GND	0	-	0.5	μA
Icc5	Average Operating Supply Current from 5.0V	At 100Mbps with heavy network traffic	-	0.4	-	mA
Icc33	Average Operating Supply Current from 3.3V	At 100Mbps with heavy network traffic	-	24	-	mA
Icc10	Average Operating Supply Current from 1.05V	At 100Mbps with heavy network traffic	-	60	-	mA

Note: Refer to the latest schematic circuit for correct configuration.

7.7. Reflow Profile Recommendations

Table 26. Reflow Profile Recommendations

Profile Feature	Sn-Pb Eutectic Assembly	Pb-Free Assembly
Minimum Preheat Temperature (T _{sm} _{in})	100°C	150°C
Maximum Preheat Temperature (T _{sm} _{ax})	150°C	200°C
Preheat Time (t _s) from T _{sm} _{in} to T _{sm} _{ax}	60~120 seconds	60~120 seconds
Ramp-Up Rate (T _L to T _p)	3°C/second max.	3°C/second max.
Liquidus Temperature (T _L)	183°C	217°C
Time (t _L) Maintained above T _L	60~150 seconds	60~150 seconds
Peak Package Body Temperature (T _p)	235°C	260°C
Time (t _p) ² within 5°C of Peak T _p	20 seconds	20 seconds
Ramp-Down Rate (T _p to T _L)	6°C/second max.	6°C/second max.
Time 25°C to Peak Temperature (T _p)	6 minutes max.	8 minutes max.

Note 1: All temperatures refer to the topside of the package, measured on the package body surface.

Note 2: Tolerance for T_p is defined as a supplier's minimum and a user's maximum.

Note 3: Reference document: IPC/JEDEC J-STD-020D.1.

7.8. AC Characteristics

7.8.1. SPI EEPROM Interface Timing

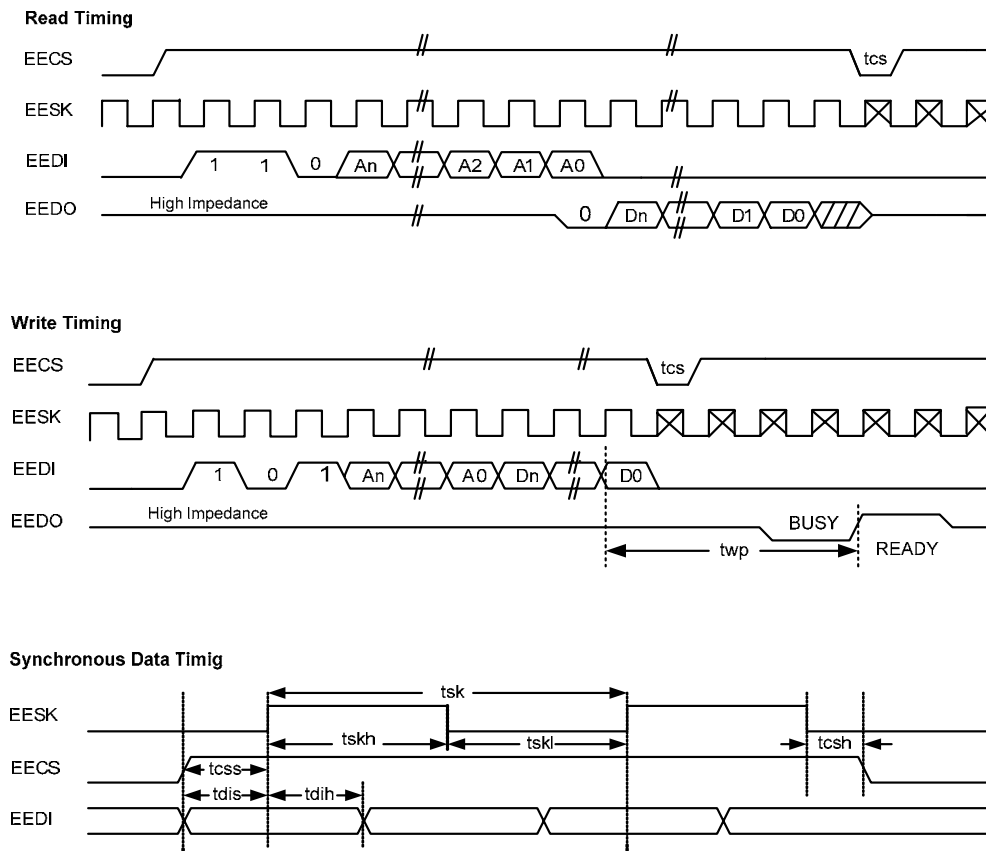

Figure 3. SPI EEPROM Interface Timing

Table 27. SPI EEPROM Access Timing Parameters

Symbol	Parameter	Min	Typical	Max	Unit
tcs	Minimum CS Low Time	1024	4096	-	ns
tcss	CS Setup Time	512	512	-	ns
tcs	CS Hold Time	-	0	-	ns
tskh	SK High Time	512	512	8192	ns
tskl	SK Low Time	512	512	8192	ns
tsk	SK Clock Cycle Time	1024	1024	16384	ns
tdis	DI Setup Time	512	512	-	ns
tdih	DI Hold Time	512	512	-	ns
twp	Write Cycle Time	-	6	10	ms

7.8.2. TWSI EEPROM Interface Timing

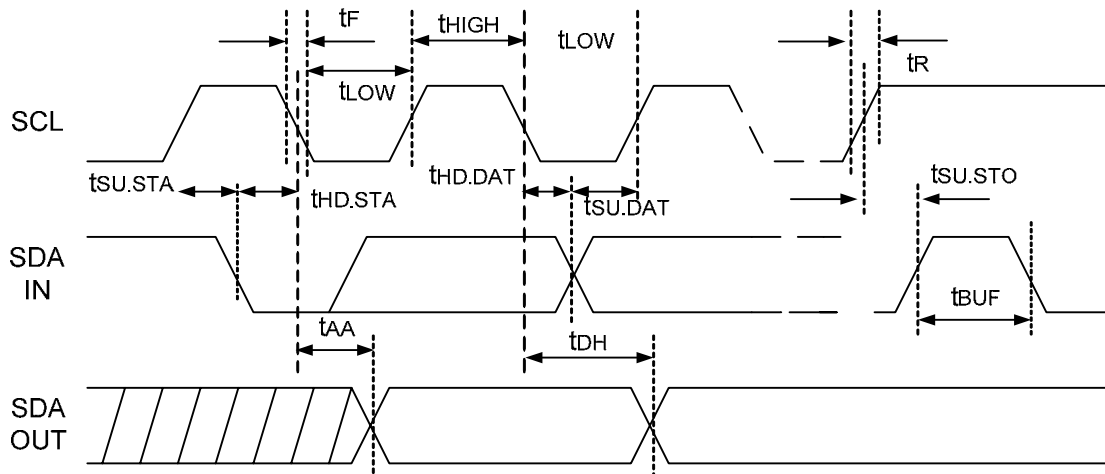

Figure 4. TWSI EEPROM Interface Timing-1

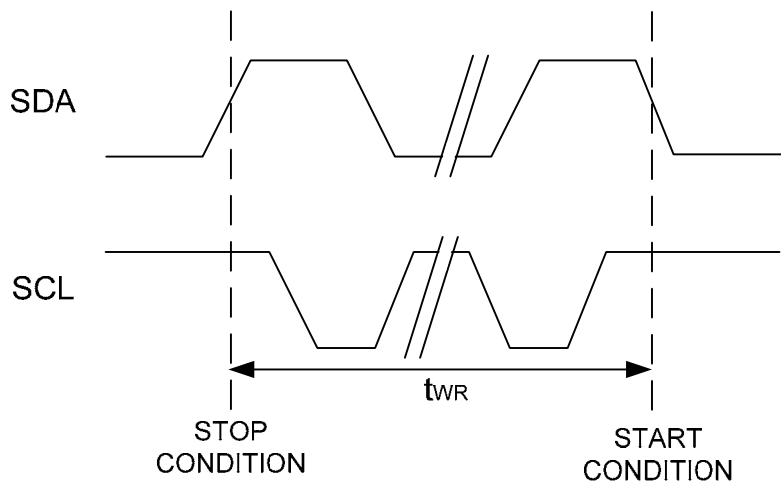
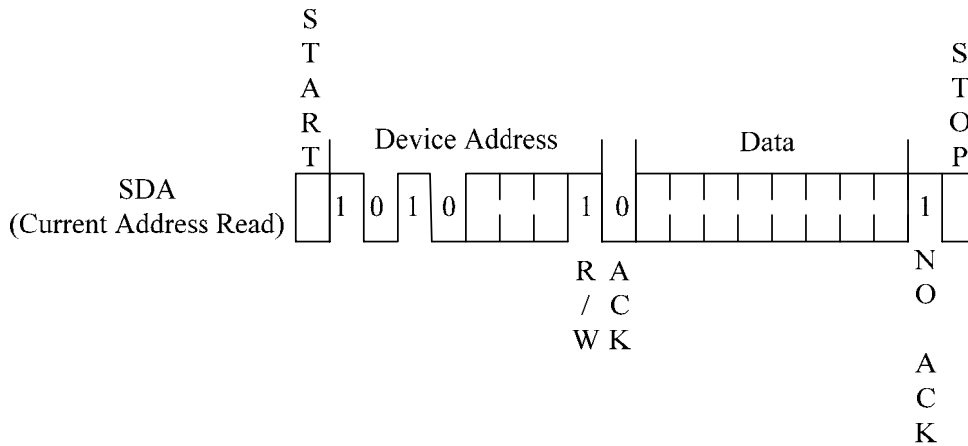
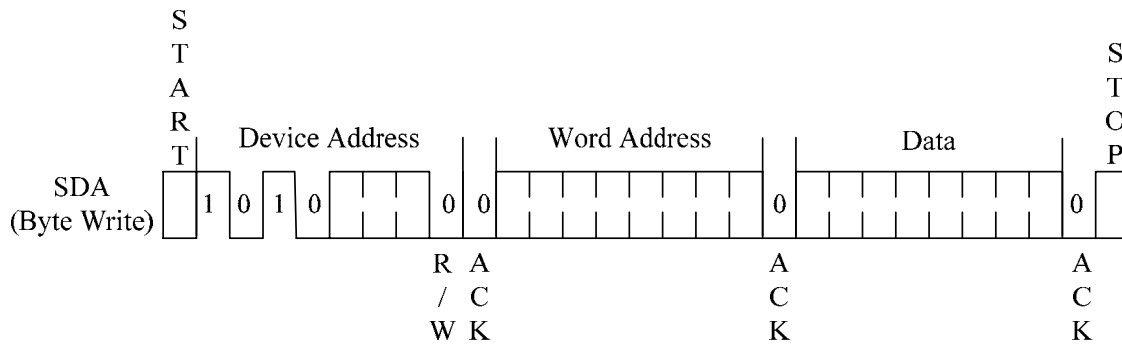

Figure 5. TWSI EEPROM Interface Timing-2

Figure 6. TWSI EEPROM Interface Timing-3

Figure 7. TWSI EEPROM Interface Timing-4
Table 28. TWSI EEPROM Access Timing Parameters

Symbol	Parameter	Min	Typical	Max	Unit
t_{LOW}	Clock Pulse Width Low	512	-	8192	ns
t_{HIGH}	Clock Pulse Width High	512	-	8192	ns
t_{AA}	Clock Low to DO Valid		504	514	ns
t_{BUF}	Time the Bus Must be Free before a New Transmission Can Start	-	-	-	ns
$t_{HD.STA}$	Start Hold Time	247	252	257	ns
$t_{SU.STA}$	Start Setup Time	247	252	257	ns
$t_{HD.DAT}$	DI Hold Time	247	252	257	ns
$t_{SU.DAT}$	DI Setup Time	247	252	257	ns
t_R	Input Rise Time	-	-	-	ns
t_F	Input Fall Time	-	-	-	ns
$t_{SU.STO}$	Stop Setup Time	494	504	514	ns
t_{DH}	DO Hold Time	494	504	514	ns
t_{WR}	Write Cycle Time	5.88	6	6.12	ms

7.8.3. SPI Flash Commands

Table 29. SPI Flash Commands

Command	Operation Code	Action
WREN	06h	Write Enable
WRDI	04h	Write Disable
RDID	9Fh	Read Manufacturer and Product ID
RDSR	05h	Read Status Register
WRSR	01h	Write Status Register
Read	03h	Read
Page Program	02h	Page Program
Sector Erase (4K)	20h	Erase The Selected Sector
Block Erase (64K)	D8h	Erase The Selected Block
Chip Erase	60h or C7h	Erase Whole Chip

7.8.4. SPI Flash Interface Timing Sequences

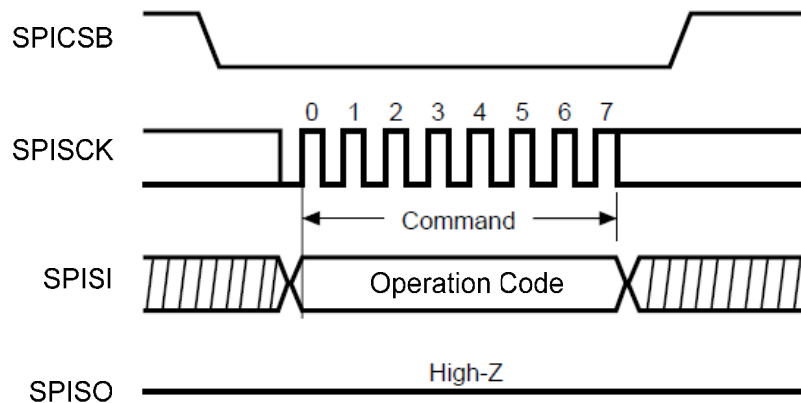
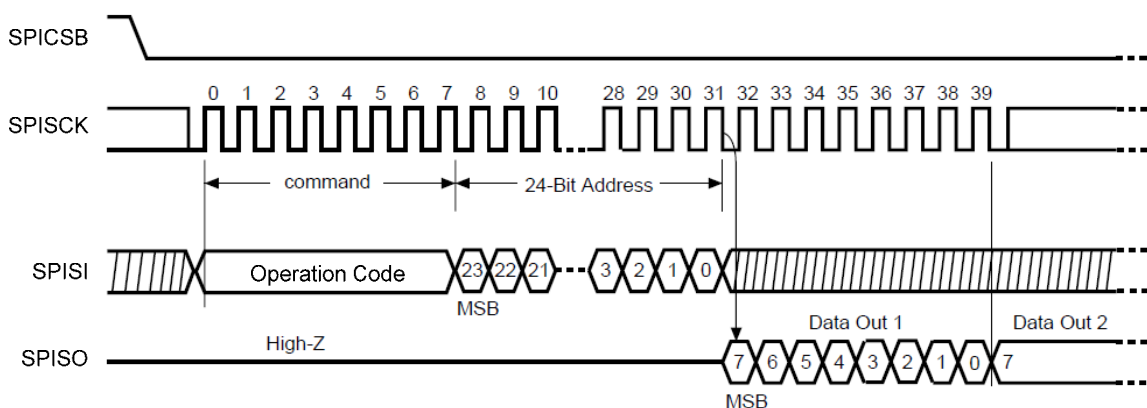
Figure 8. WREN/WRDI Timing Sequence

Figure 9. Read Timing Sequence

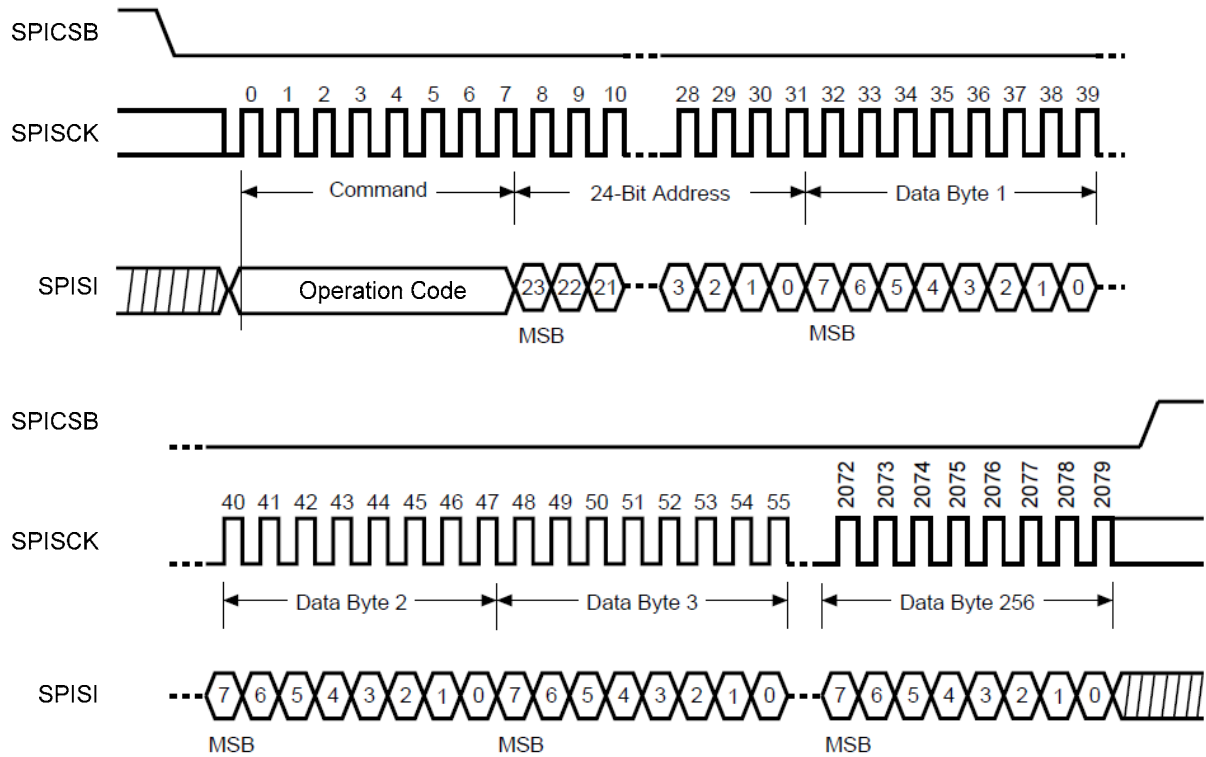

Figure 10. Page Program Timing Sequence

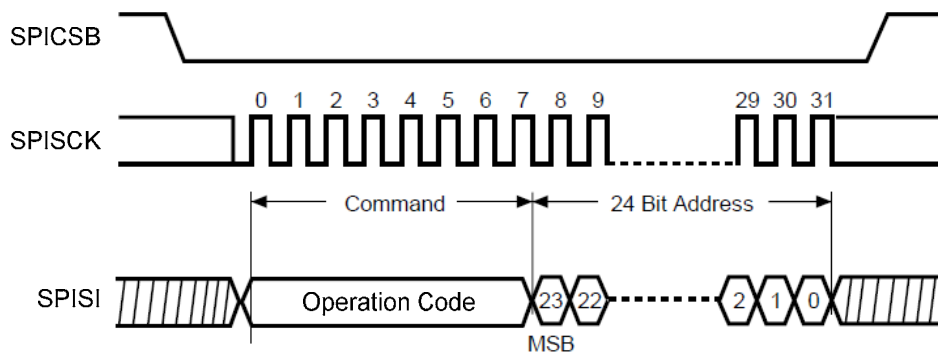

Figure 11. Sector/Block Erase Timing Sequence

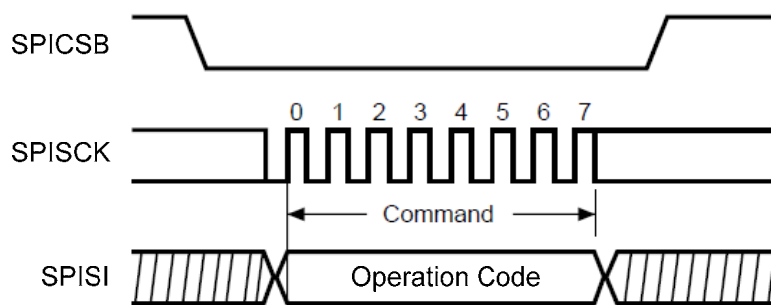

Figure 12. Chip Erase Timing Sequence

7.8.5. SPI Flash Type Supported

Table 30. SPI Flash Type Supported

Manufacturer	Flash Part No.	Density (Mb)	Maximum Freq. (MHz)
MXIC	MX25L4006E	4	86
	MX25L8006E	8	86
	MX25L1606E	16	86
Winbond	W25X40CV	4	80
	W25Q40BV	4	80
	W25Q80BV	8	80
	W25Q16CV	16	80
Numonyx	M25P40	4	75
	M25PX80	8	75
	M25PX16	16	75

Note 1: The Flash clock frequency should be 33MHz or higher.

Note 2: Flash density should be 4Mb or more. 4Mb is only for single OS driver. For feature extensions, 8Mb is recommended.

8. Mechanical Dimensions

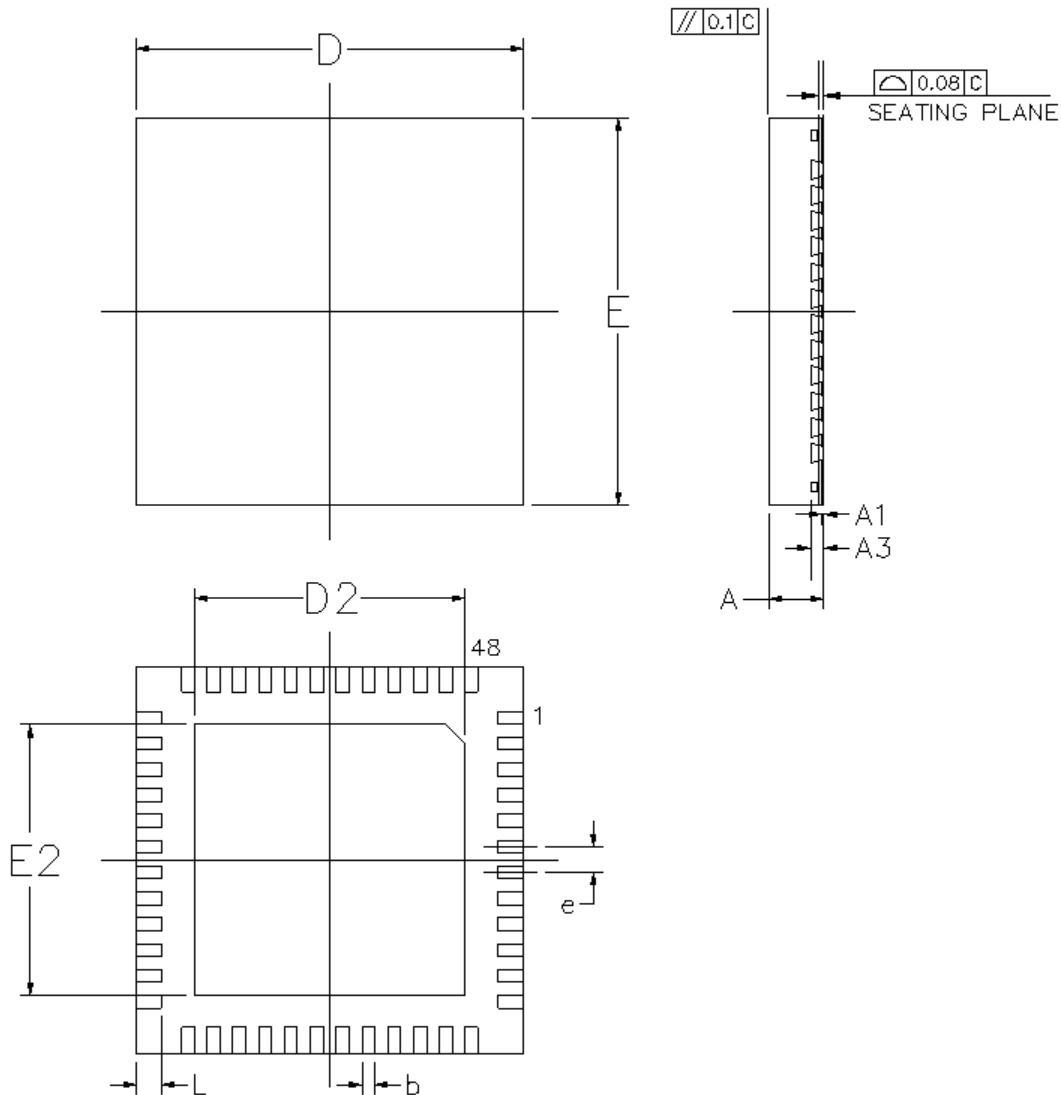

Symbol	Dimension in mm			Dimension in inch		
	Min	Nom	Max	Min	Nom	Max
A	0.75	0.85	1.00	0.030	0.034	0.039
A ₁	0.00	0.02	0.05	0.000	0.001	0.002
A ₃	0.20REF			0.008REF		
b	0.15	0.20	0.25	0.006	0.008	0.010
D/E	6.00BSC			0.236BSC		
D2/E2	4.15	4.4	4.65	0.163	0.173	0.183
e	0.40BSC			0.016BSC		
L	0.30	0.40	0.50	0.012	0.016	0.020

Note 1: CONTROLLING DIMENSION: MILLIMETER (mm).

Note 2: REFERENCE DOCUMENT: JEDEC MO-220.

9. Ordering Information

Table 31. Ordering Information

Part Number	Package	Status
RTL8152BN-VB-CG	48-Pin QFN 'Green' Package	-

Note: See page 4 for package ID information.

Realtek Semiconductor Corp.**Headquarters**

No. 2, Innovation Road II
Hsinchu Science Park, Hsinchu 300, Taiwan
Tel.: +886-3-578-0211. Fax: +886-3-577-6047
www.realtek.com