



# OV4689 4MP product brief



## High Frame Rate 4-Megapixel CameraChip™ Sensor with Excellent Low-Light Sensitivity and High Dynamic Range for Security Applications



available in a lead-free package

The OV4689 is a high performance 4-megapixel CameraChip sensor in a native 16:9 format designed for next-generation surveillance and security systems. The sensor utilizes an advanced 2-micron OmniBSI-2™ pixel to provide best-in-class low-light sensitivity and high dynamic range (HDR).

The 1/3-inch OV4689 can capture full-resolution 4-megapixel high definition (HD) video at 90 frames per second (fps), 1080p HD at 120 fps, and binned 720p HD at 180 fps. The sensor's high frame rates enable crisp, clean image and video capture of fast moving objects.

The OV4689 provides timing to capture full-resolution HDR using frame-based "sequential HDR" or line-based "staggered HDR", and quarter resolution HDR using

"alternate row HDR". The benefits of using "staggered HDR" compared to "sequential HDR" are significant reduction in motion artifacts and lower memory requirement for host processing. These modes produce high quality full-resolution 4-megapixel HDR video under extreme variations of bright and dark conditions, ensuring high contrast and excellent scene reproduction.

The OV4689 features a high-speed 4-lane MIPI serial output interface to facilitate the required high data transfer rate. The OV4689 is available in a chip scale package (CSP).

Find out more at [www.ovt.com](http://www.ovt.com).



## Applications

- Security and Surveillance

## Product Features

- automatic black level calibration (ABLC)
- programmable controls for frame rate, mirror and flip, cropping, and windowing
- static defective pixel canceling
- supports output formats: 10-bit RAW RGB (MIPI)
- supports horizontal and vertical subsampling
- supports images sizes: 4MP, 3MP, EIS1080p, 1080p, EIS720p
- fast mode switching
- support 2x2 binning, 4x4 binning, re-sampling filter
- standard serial SCCB interface
- up to 4-lane MIPI serial output interface
- embedded 4K bits one-time programmable (OTP) memory for part identification, etc
- two on-chip phase lock loops (PLLs)
- programmable I/O drive capability
- built-in temperature sensor
- supports staggered, sequential and alternative row HDR timing

# OV4689

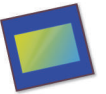

## Ordering Information

- OV04689-H67A  
(color, lead-free, 67-pin CSP5)

## Product Specifications

- active array size: 2688 x 1520
- max S/N ratio: 38.3 dB
- power supply:
  - core: 1.1 - 1.3V
  - analog: 2.6 - 3.0V
  - I/O: 1.7 - 3.0V
- power requirements:
  - active: 163 mA (261 mW)
  - standby: 1 mA
  - XSHUTDOWN: <10  $\mu$ A
- temperature range:
  - operating: -30°C to +85°C junction temperature
  - stable image: 0°C to +60°C junction temperature
- output formats: 10-bit RAW RGB data
- lens size: 1/3"
- input clock frequency: 6 - 64 MHz
- lens chief ray angle: 0°
- dynamic range: 64.6 dB @ 1x gain
- maximum image transfer rate:
  - 2688x1520: 90 fps
  - 1280x720: 180 fps
  - 1920x1080: 120 fps
- sensitivity: 1900 mV/lux-sec
- scan mode: progressive
- maximum exposure interval: 1548 x T<sub>ROW</sub>
- pixel size: 2  $\mu$ m x 2  $\mu$ m
- dark current: 4 mV/sec @ 60°C junction temperature
- image area: 5440  $\mu$ m x 3072  $\mu$ m
- die dimensions: 6630  $\mu$ m x 5830  $\mu$ m

## Functional Block Diagram

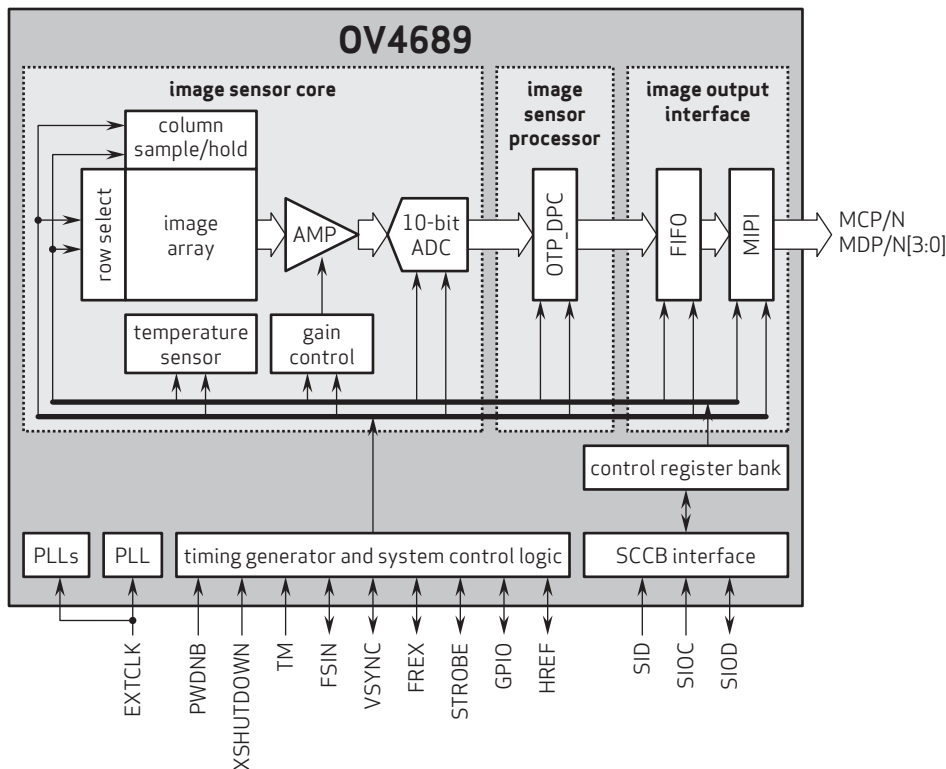

4275 Burton Drive  
Santa Clara, CA 95054  
USA

Tel: + 1 408 567 3000  
Fax: + 1 408 567 3001  
www.ovt.com

OmniVision reserves the right to make changes to their products or to discontinue any product or service without further notice. OmniVision and the OmniVision logo are registered trademarks of OmniVision Technologies, Inc. CameraChip, OmniBSI-2, OmniBSI+ and OmniBSI are trademarks of OmniVision Technologies, Inc. All other trademarks are the property of their respective owners.



OmniVision